



**OUNDLE**

School

---

## EXAMINATION PAPER

### Junior Entry 2022

## Science

Time allowed: 1 hour

Name: \_\_\_\_\_

#### Instructions

- You have **5 minutes reading time**. In this time, you should read the whole paper and choose which questions you are going to answer.
- Answer only **3** of the 5 questions, the choice is up to you.
- You have **55 minutes to answer your 3 questions**.
- You will need a pen, pencil, ruler and calculator.

1) This question is about **identifying solids** and **reversible** and **non-reversible changes**.

a) Mia has four different solids. Her teacher asks her to find out what the solids are. Mia mixes a teaspoon of each solid into different beakers of water. She records her observations in Table 1.

Solid	Observation after mixing with water
A	Most solid floats on top of the water. The solid turns the water misty
B	The solid cannot be seen. The liquid is clear.
C	The solid cannot be seen. The liquid is clear.
D	Some solid sinks to the bottom. The solid turns the water cloudy.

What is the name of the process that happens to solids B and C?

---

[1]

b) Mia tries to separate a mixture of solids A and D using a sieve. Mia records her observations as shown in the table below.

Solid	Observation after mixing with water
A	The solid stays in the sieve.
D	The solid goes through the sieve.

Describe ONE difference between solids A and D that stops solid A going through the sieve.

---

---

---

[1]

- c) Next Mia puts a teaspoon of solid B into a beaker of vinegar. Then she puts a teaspoon of solid C into another beaker of vinegar. She records her observations as shown in the table below.

Solid	Observation after mixing with water
B	The solid cannot be seen. The liquid is clear.
C	The mixture bubbles and fizzes.

- i) Which solid has a non-reversible change when mixed with vinegar?

\_\_\_\_\_ [1]

- ii) What evidence shows the change to the solid you chose is non-reversible?



\_\_\_\_\_ [1]

- d) The teacher tells Mia the names of the four solids.

Draw FOUR lines to match each solid to its name. Use the information in the previous tables in this question to help you.

**Solid**    A    B    C    D

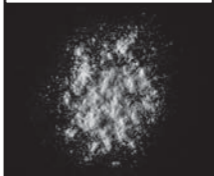
**Name of solid**

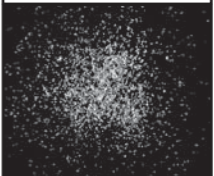
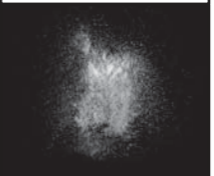
flour	coconut	salt	bicarbonate of soda
			

[2]

e) Mia decides to investigate candles. She makes the following statement;

“When a candle burns, a non-reversible changes happens”

Complete the table to show if the observation is evidence of a reversible or a non-reversible change. Tick ONE box in each row.

Observation	This is evidence of a reversible change.	This is evidence of a non-reversible change.
The wax melts		
Smoke is given off		

[1]

f) Mia has candles of different heights but the same width. She wants to burn them all down to a height of 1cm.



Describe the relationship between the height of the candle and the time it takes the candle to burn down to 1 cm.

---

---

[1]

- g) Mia has three new candles. They are the same height but have different widths.

Mia wants to find out if the width of the candle affects the time it takes to burn down. She times how long it takes for each candle to burn down to 1cm.

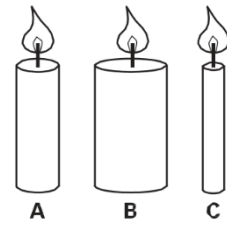

The graph below shows Mia's results.

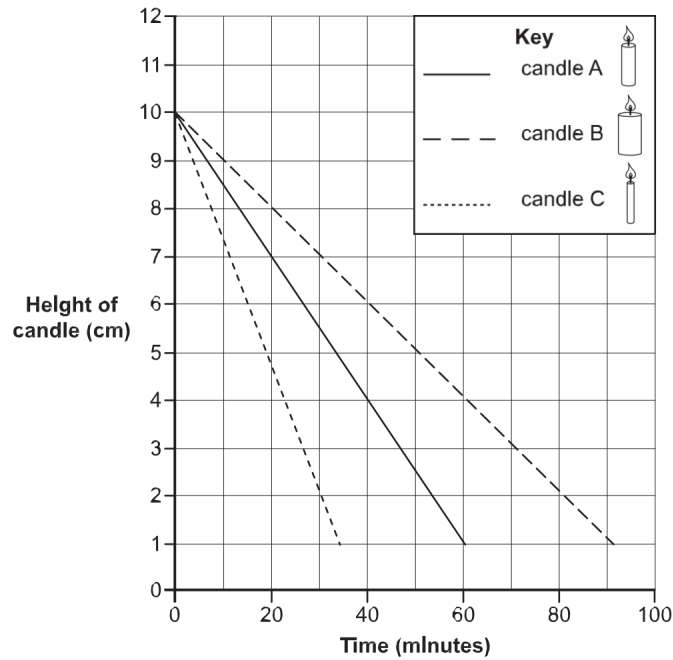

Candle C burnt down the quickest.

How many minutes did it take candle C to burn down to 4 cm?

---

[1]

- h) Mia has another candle. It is thinner than candle C but it is the same height.  
Draw a line on the graph to show how quickly the new candle will burn down to 1 cm.

[1]  
[Total: 10]

2) This question is about **changes in state** of materials.

a) Alex makes a cake for an investigation.

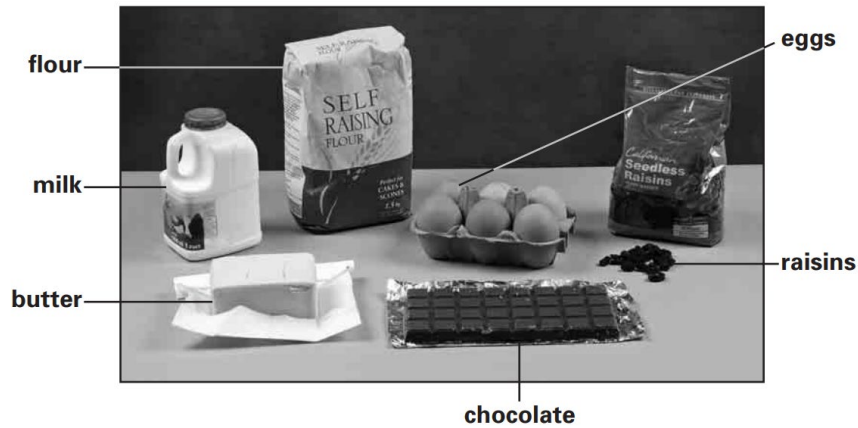

He accidentally leaves the solid butter near the oven and it becomes a liquid.

What is the name of this change of state?

---

[1]

b) Alex places the cake mixture in the oven, but when he removes it, he notices it that it is 'steaming'. He concludes that this must be due to the water in the ingredients changing state.

What is the name of this change of state?

---

[1]

c) Alex cuts the cake in half. He notices holes in the cake. What is inside these small spaces?

---

[1]

d) Alex decides to do some further investigations regarding the changes in states of substances.

He finds some data regarding the freezing points of some related chemicals.

Capric acid	32°C
Formic acid	8°C
Palmitic acid	63°C

The boiling point of these compounds is above 100°C.

Plot the data of the freezing points on the graph on page 6.

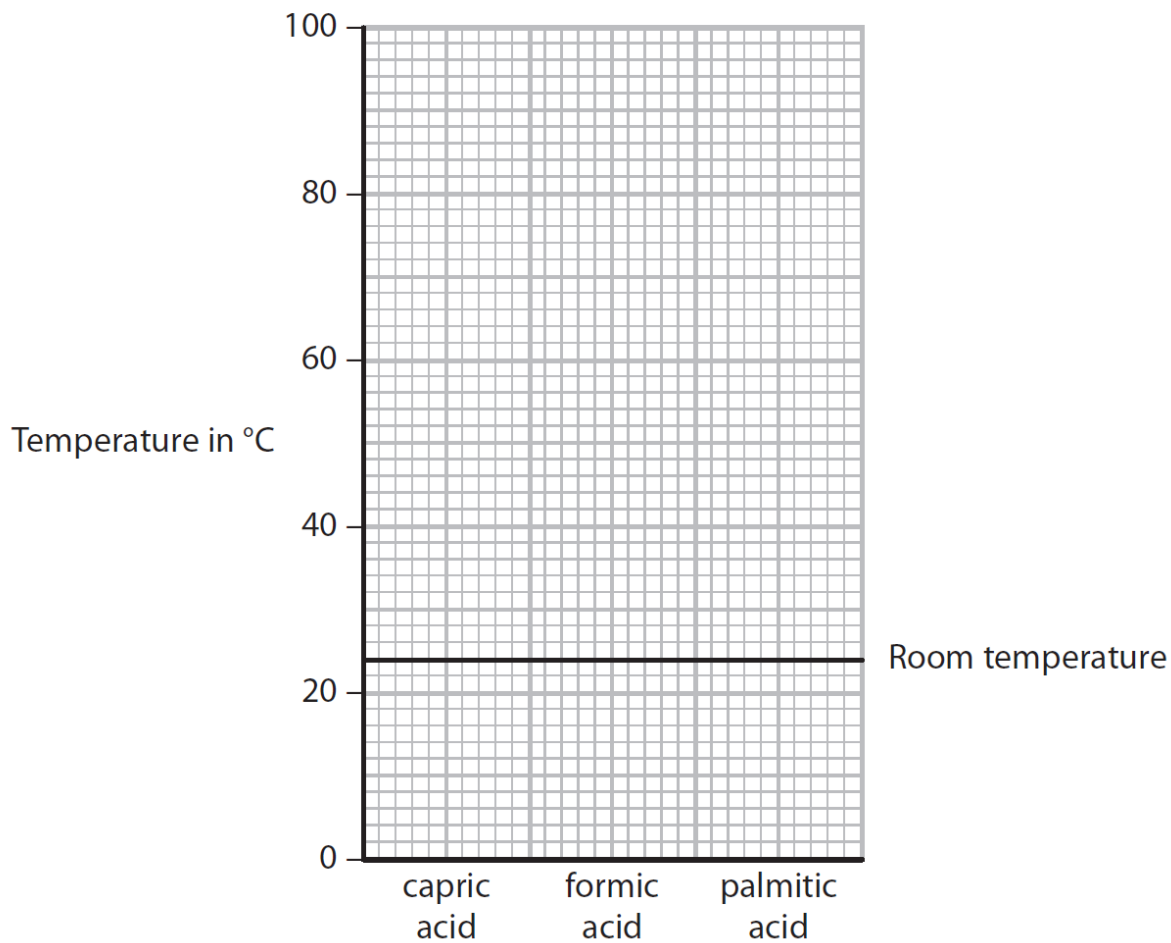

[2]

e) Room temperature has been marked on the graph.

Use your graph to give the physical state of each chemical at room temperature.

Capric acid \_\_\_\_\_

Formic acid \_\_\_\_\_

Palmitic acid \_\_\_\_\_

[2]

- f) The particles in a solid are closely packed, arranged in a regular pattern and vibrate about a fixed position.

Describe the arrangement and movement of the particles in a gas.

---

---

---

[3]

[Total: 10]



3) This question is about finding the best fabric for a bathmat.

Some children want to find the best fabric for making a bathmat. They set up two different tests.



**TEST 1 - Does the fabric slip easily on a smooth surface?**

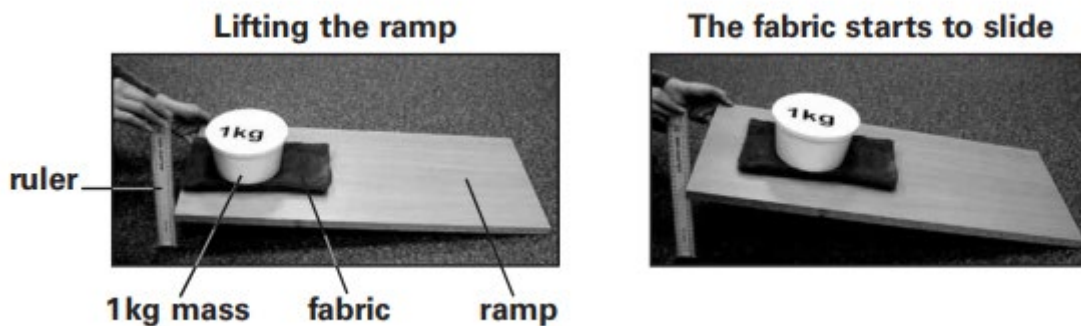

They slowly lift the ramp until the fabric starts to slide.  
Here are the results of Test 1:

Fabric	Height of ramp when fabric starts to slide (cm)
A	11
B	8
C	13
D	16

Look at the table.

a) Put the fabrics in order to show how easily each fabric slipped.

**Slipped easily**                    **Did not slip easily**

b) What is the name of the force that makes it hard for the fabric to start moving?

---

[1]

**TEST 2 - Does the fabric absorb water?**

The children pour the same amount of water onto each fabric. They hold up the fabric to let the water drip off.

Here are the results of Test 2:

Fabric	Observations
A	Almost no water drips off.
B	Nearly all the water drips off.
C	Some of the water drips off.
D	No water drips off.

c) Put the fabrics in order to show how absorbent each fabric was.

Most absorbent     Least absorbent

[1]

Look at the results of Test 1 and Test 2

d) Which fabric will make the best bathmat?

\_\_\_\_\_ [1]

e) Give TWO reasons why the fabric you chose is better than the other fabrics.

1. \_\_\_\_\_
  2. \_\_\_\_\_
- [2]

f) The pupils then decide to investigate the time taken for different types of mat to slide down a ramp at a fixed angle.

What would they use to measure the time for each mat to slide down the ramp?

\_\_\_\_\_ [1]

g) Which unit of measurement should they use to record the time taken for the mat to slide down the ramp? Tick the correct box. [1]

hours  N  cm  g  s

h) Which factor do they change as they carry out their investigation?

Put a tick in the correct box.

[1]

the angle of the ramp	<input type="checkbox"/>	the length of the ramp	<input type="checkbox"/>
the type of mat	<input type="checkbox"/>	the person recording the results	<input type="checkbox"/>
the surface of the ramp	<input type="checkbox"/>	the distance each mat moves down the ramp	<input type="checkbox"/>

i) Which three factors should they keep the same in their investigation?

Tick the three correct boxes.

[1]

the angle of the ramp	<input type="checkbox"/>	the length of the ramp	<input type="checkbox"/>
the type of mat	<input type="checkbox"/>	the colour of each mat	<input type="checkbox"/>
the surface of the ramp	<input type="checkbox"/>	the time the mat takes to reach the bottom of the ramp	<input type="checkbox"/>

[Total: 10]

4) This question is about **circuits**.

a) James decided to investigate how the position and brightness of the sun affects the size and shape of shadows. To do this he made different circuits using the same type of bulbs, motors with fans and cells (batteries).

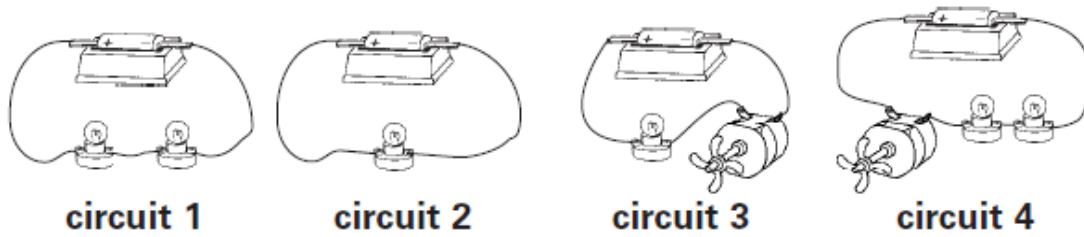

In which circuit will the bulb or bulbs be brightest?

Explain why the circuit you chose has the brightest bulb or bulbs.

Circuit: \_\_\_\_\_

Explanation: \_\_\_\_\_

---

---

---

---

[2]

b) Draw a line from each electrical circuit to the correct circuit diagram. Draw only four lines.

**electrical circuit**

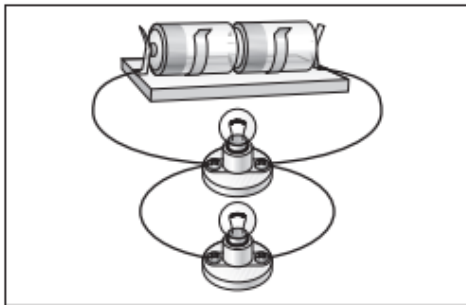
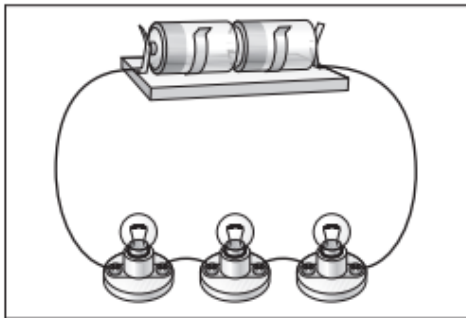
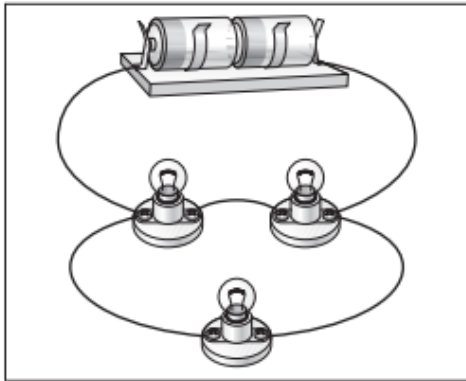
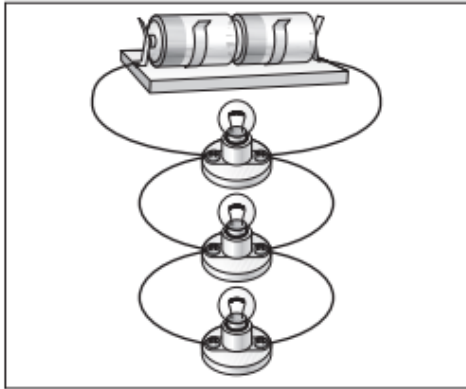

**circuit diagram**

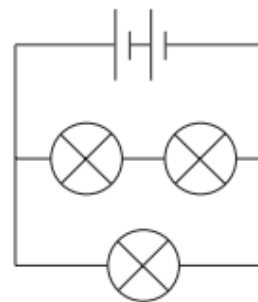
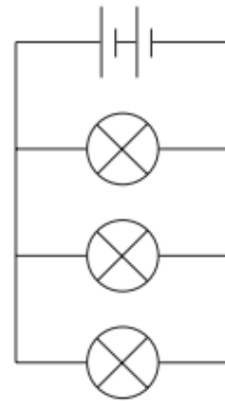
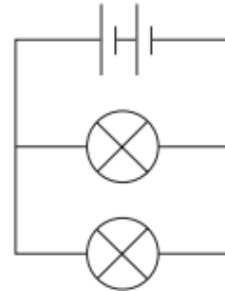
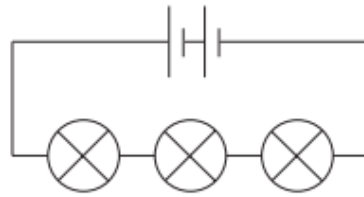

[2]

- c) In each circuit below, bulb 1 **breaks** and goes off. Under each circuit diagram below, tick the correct boxes to show if bulb 2 and bulb 3 are on or off.

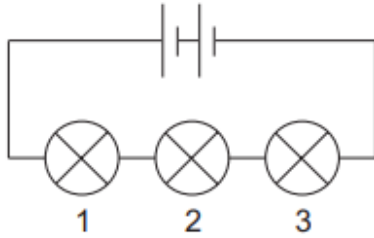

**circuit A**

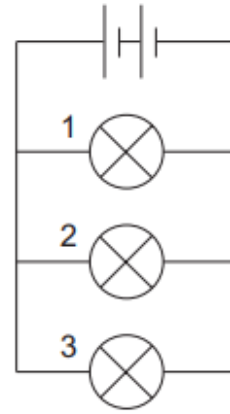

**circuit B**

	on	off
<b>bulb 1 breaks</b>		✓
<b>bulb 2</b>		
<b>bulb 3</b>		

	on	off
<b>bulb 1 breaks</b>		✓
<b>bulb 2</b>		
<b>bulb 3</b>		

[2]

- d) Give the name of the part that provides energy for each circuit.

---

[1]

- e) Why is copper used for wires in a circuit? Tick the correct box.

Copper does **not** stick to a magnet.

Copper is a good conductor of electricity.

Copper is a brown metal.

Copper is a good conductor of heat.

[1]

f) A student uses four ammeters P, Q, R and S to measure the current in different parts of the circuit shown.

[2]

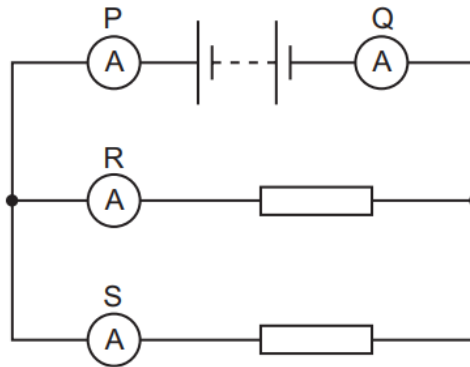

Which two ammeters read the largest current? Circle the correct answer:

**A** P and Q

**B** P and R

**C** R and Q

**D** R and S

[Total: 10]

5) This question is about being **'made for the job'**.

a) Draw lines to match up the words in the first column with the descriptions in the second column.

Stomach	Pumps blood around an animal's body.
Heart	Removes impurities from the blood.
Lungs	Controls many of the life processes in animals.
Kidneys	Allows oxygen to enter the body.
Brain	Stores and churns food.
Liver	Deals with food taken into the body from the intestines.

[3]

b) On the outline of a human body, mark on it where you would find the brain, heart, lungs, stomach, intestines, liver and kidneys.

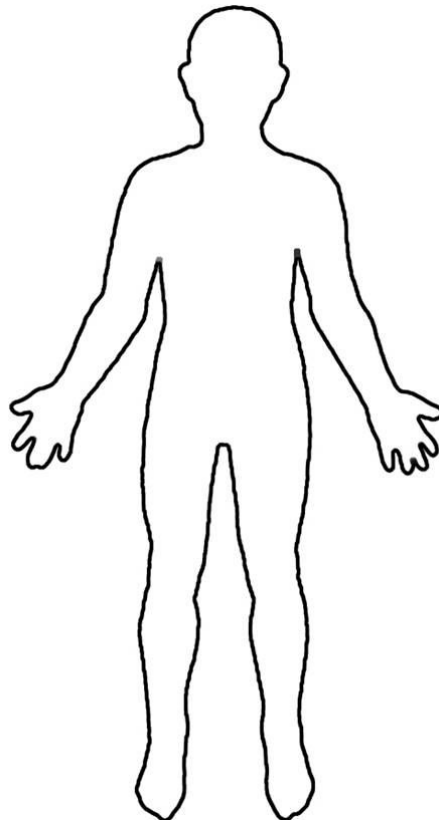

[3]



c) Bioman went to the doctor for a check-up. The doctor listened to his heart with a stethoscope.

The doctor then asked Bioman whether he took much exercise.

Why does exercise make your heart beat faster and your lungs breathe deeper?

---

---

---

---

---

---

---

---

---

---

---

[4]

**End of Paper**