



KING'S COLLEGE JUNIOR SCHOOL
WIMBLEDON

SPECIMEN PAPER

GROUP E

MATHEMATICS

Time Allowed: 45 minutes

Name: _____

INSTRUCTIONS

You will need a pencil and a ruler.

No Calculator allowed.

Write your answers in the spaces provided on this paper.

Use any spare space on the page for working out.

If you have time at the end, check your answers carefully.

Try to answer as many questions as you can.

If you cannot do a question, leave it and move onto the next question.

1) Work out the following, showing all your working.

a) Bobby was given some money for his birthday.

He decided to buy a calendar for £6.97 and a ball for £2.99.

How much did he spend?

b) He has £5.04 left in his wallet.

How much did he originally have in his wallet?

c) Multiply together 293 and 74

d) Divide 9380 by 35

2) Solve each of these equations below to find the value of x.

a) $x - 4 = 17$

b) $5x = 55$

c) $\frac{x}{10} = 6$

d) $14 + x = 23$

e) $\frac{1}{4}x = 7$

f) $7x = 37$

3) Solve the following two step equations, below, to find the value of x.

a) $5x - 9 = 6$

b) $\frac{x}{5} + 9 = 16$

c) $17 = 2 + 3x$

d) $7x + 15 = 1$

4) Form an equation for each of the following problems and then solve the equation :

a) I think of a number, multiply it by 9, and the result is 36.

What is the number I first thought of?

b) I think of a number, multiply it by 6 and then subtract 5. The result is 37.

What is the number I first thought of?

5) a) What is the volume of a rectangular box which is 5cm long, 20cm wide and 10cm high?

b) How many 5cm cubes can be packed into the rectangular box in part a) ?

6) Calculate the following, using the most appropriate unit for your answers.

a) $\frac{3}{8}$ of 11.2m

b) 0.3×2 kg

c) 28% of £50

d) 60% of £250

e) $\frac{3}{8}$ of £8.22

- 7) The total running time for a film is 100 minutes.
3% of the time is taken up with the opening title sequence and final credits.
A total of 25 minutes of the film is shot outdoors.
One-fifth of the film is shot inside a hospital.
0.17 of the film is shot in a greenhouse.
All the remainder of the film is shot inside The Manor House.

How much of the film is shot inside The Manor House?

Answer as

- a) A fraction: _____ b) A decimal: _____
c) A percentage: _____ d) In minutes: _____

- 8) Find the next number in each of these sequences:

a) 1, 4, 8, 13, 19, _____

b) 1, 2, 4, 8, 16, _____

c) 100, 99, 96, 91, 84, _____

d) 89, 55, 34, 21, 13, _____

Find the missing number in this sequence:

e) 1, 8, 27, _____, 125, 216

9) a)

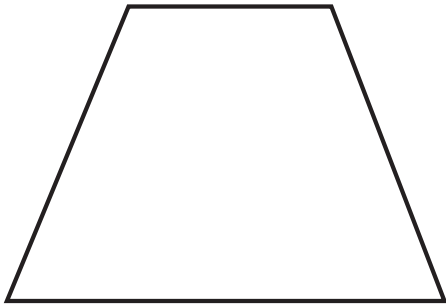

b)

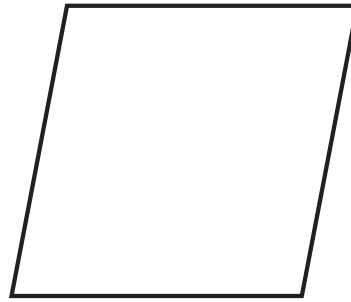

On the two shapes above draw the correct signs onto the shapes to show:

a) its equal sides b) its equal angles c) its parallel sides

10) Complete the following using the lettered points in the frame.

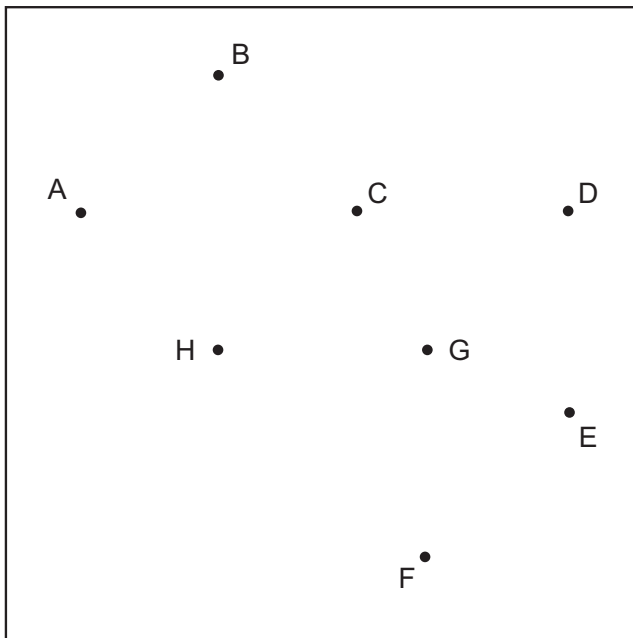

Example: Square A B C H

a) Rectangle C E _____

b) Isosceles triangle B D _____

c) Parallelogram G F _____

d) Isosceles Trapezium A H _____

11) Here are 4 shapes

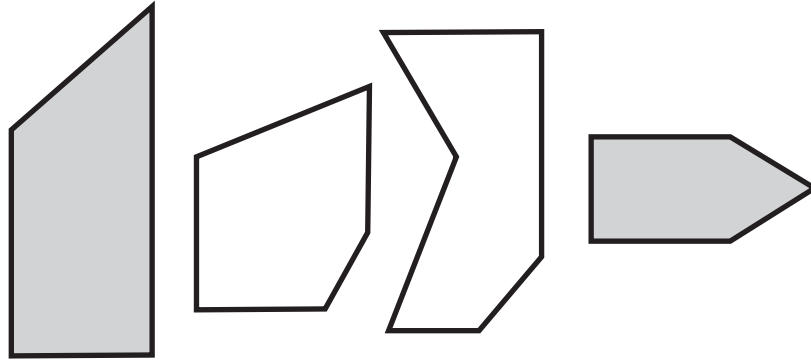

Each shape has **two parallel sides**.

Write **TWO** other things which are the **same** about **ALL** the 4 shapes.

a) _____

b) _____

12) Explain why it is **not possible** for a quadrilateral to have **exactly** three right-angles.

13) Calculate the size of the missing angles
(DIAGRAMS ARE NOT DRAWN TO SCALE)

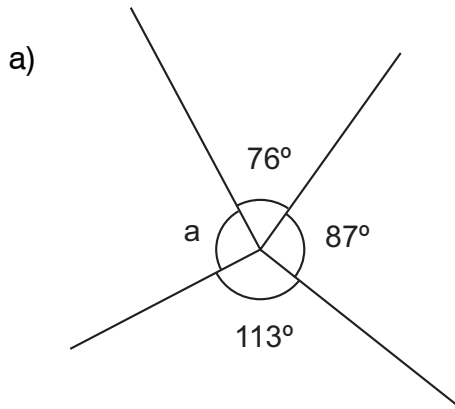

$a = \underline{\hspace{2cm}}^\circ$

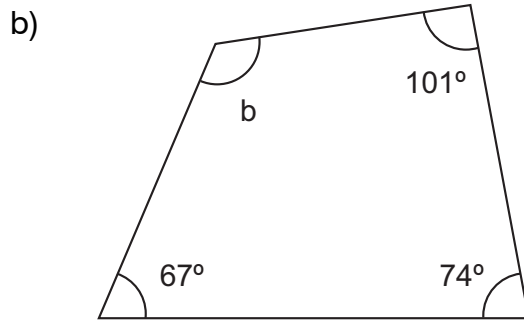

$b = \underline{\hspace{2cm}}^\circ$

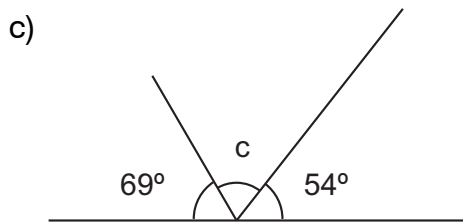

$c = \underline{\hspace{2cm}}^\circ$

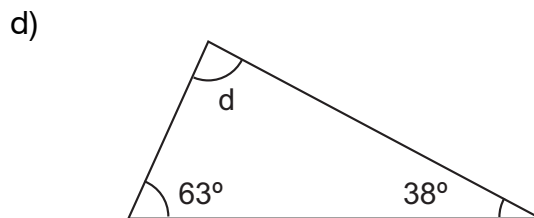

$d = \underline{\hspace{2cm}}^\circ$

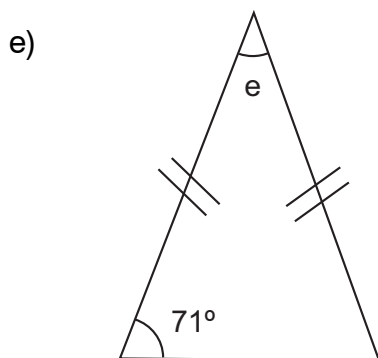

$e = \underline{\hspace{2cm}}^\circ$

- 14) In a money bag there are an equal number of 2p's, 5p's and no other coins.
How many coins are in the bag if altogether there is £1.26?

- 15) A recipe for a pudding for 6 people requires the ingredients listed in the box on the right.

<p><i>3 eggs</i> <i>240g flour</i> <i>90g sultanas</i> <i>150ml milk</i> <i>45g butter</i></p>
--

I want to adapt this recipe to make a similar pudding to serve 8 people.

- a) For 8 people I would need _____ eggs and _____ ml of milk.

If instead I wanted to make the pudding for 9 people then ...

- b) For 9 people I would need _____ g of sultanas and _____ g of butter.

Later, I find the recipe for the same pudding in a recipe book, but this version calls for 5 eggs.

- c) How many people is this 5 egg version intended to serve? It serves _____.

- d) In the 5 egg version, you would need to use _____ g of flour.

16) Harry invents a game which he calls King's Digit.

For any number he chooses, he works out all the whole numbers that divide exactly into it.

For example, if he chooses the number 8, then all the whole numbers that divide exactly into that are 1, 2, 4 and 8. These are called the factors of 8.

He then adds up these factors to find the King's Digit.

So the Kings digit of $8 = 1 + 2 + 4 + 8 = 15$

Another example: the King's Digit of 9 is $1 + 3 + 9 = 13$.

a) Find the Kings Digit of 16.

b) If the Kings Digit of a number = 7, what is the number?

c) If the King's digit of a number = 12, there are two possible numbers.

What are they?

_____ , _____

d) The King's digit of three different numbers = 24. Two of them are consecutive numbers. Find the three numbers.

_____ , _____ , _____

END OF THE TEST. CHECK YOUR WORK IF YOU HAVE TIME.